

Quest

QSR5000

DOLBY DIGITAL SURROUND RECEIVER

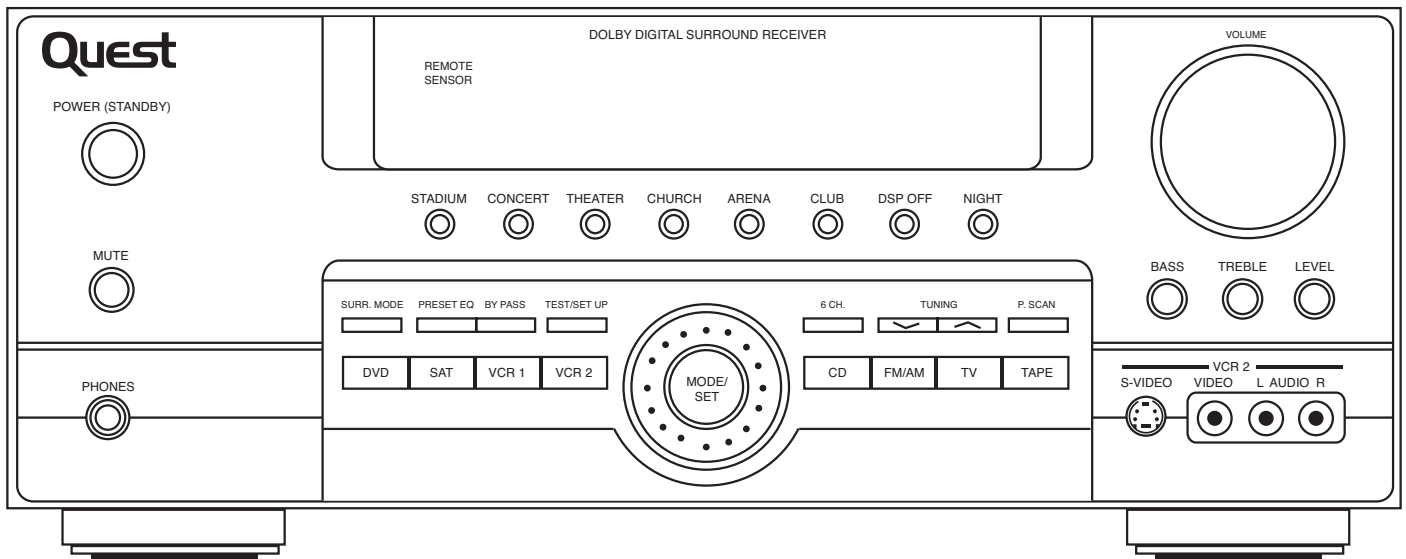

INSTRUCTIONAL MANUAL

FEDERAL COMMUNICATIONS COMMISSION (FCC) INFORMATION

This equipment has been tested and found to comply with the limits for a Class B digital device pursuant to Part 15 of the FCC Rules. These limits are designed to provide reasonable protection against harmful interference in a residential installation. This equipment generates, uses and radiates radio frequency energy and, if not installed and used in accordance with the instructions, may cause harmful interference to radio communications. However, there is no guarantee that interference will not occur in a particular installation. In accordance with FCC requirements, changes or modifications not expressly approved by Total Technology Company could void the user's authority to operate this product. This device generates and uses radio frequency (RF) energy, and if not installed and used properly, this equipment may cause interference to radio and television reception. If this equipment does cause interference to radio or television reception (which you can determine by unplugging the unit), try to correct the interference by one or more of the following measures:

- Re-orient the receiving antenna (that is, the antenna for the radio or television that is "receiving" the interference).
- Move the unit away from the equipment that is receiving interference.
- Plug the unit into a different wall outlet so that the unit and the equipment receiving interference are on different branch circuits.

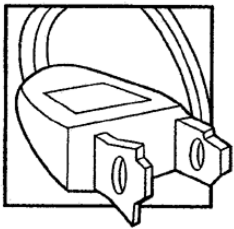

FOR YOUR SAFETY

The AC power plug is polarized (one blade is wider than the other) and only fits into AC power outlets one way. If the plug won't go into the outlet completely, turn the plug over and try to insert it the other way. If it still won't fit, contact a qualified electrician to change the outlet, or use a different one.

Do not attempt to bypass this safety feature.

CAUTION: TO PREVENT ELECTRIC SHOCK, MATCH WIDE BLADE OF PLUG TO WIDE SLOT, FULLY INSERT.

FOR YOUR RECORDS

In the event that service should be required, you may need both the model number and the serial number. In the space below, record the date and place of purchase, and the serial number:



Model No.

Remote Control No.

Date of Purchase

Place of Purchase

Serial No.

 THE LIGHTNING FLASH AND ARROW HEAD WITHIN THE TRIANGLE IS A WARNING SIGN ALERTING YOU OF "DANGEROUS VOLTAGE" INSIDE THE PRODUCT.	CAUTION RISK OF ELECTRIC SHOCK DO NOT OPEN CAUTION: TO REDUCE THE RISK OF ELECTRIC SHOCK, DO NOT REMOVE COVER (OR BACK). NO USER SERVICEABLE PARTS INSIDE. REFER SERVICING TO QUALIFIED SERVICE PERSONNEL.	 THE EXCLAMATION POINT WITHIN THE TRIANGLE IS A WARNING SIGN ALERTING YOU OF IMPORTANT INSTRUCTIONS ACCOMPANYING THE PRODUCT.
SEE MARKING ON BOTTOM/BACK OF PRODUCT		

SERVICE INFORMATION

This product should be serviced only by those specially trained in appropriate servicing techniques. For instructions on how to obtain service, refer to the warranty included in this manual.

GETTING STARTED

Unpacking the Receiver.....	2
Inserting Batteries into Remote Control.....	3
Set Up and Maintenance of the Receiver.....	3
Protect your Components from Overheating.....	3
Connecting to Audio-Visual Components.....	4
Digital Connection.....	5
Connecting Antennas.....	5
Connecting the Speakers.....	6
Connecting the Subwoofer.....	6
Positioning your Speaker.....	7
Front Speaker Placement.....	7
Advanced Setting.....	7
Preferred Surround Placement.....	8
Advanced Surround Setting.....	8
Test Tone/Channel Balance.....	8
Connecting for Power.....	8
Using Headphones.....	8

OPERATING YOUR RECEIVER

Receiver Controls.....	9
Your Remote Control.....	10
Display.....	11
Switching On/Off.....	12
Selection of Audio/Video Source.....	12
Using the Receiver to Play a Source.....	13
Operating the Radio.....	14

ADVANCED SOUND CONTROL

Sound Enhancement Systems.....	17
Fine Setting of Components.....	18

CARE AND MAINTENANCE

Receiver/Tuner Operation.....	20
Remote Control Operation.....	20
General.....	20
Cleaning the Exterior.....	20
Equipment Specifications.....	20

LIMITED WARRANTY

Limited Warranty.....	21
-----------------------	----

GETTING STARTED

UNPACKING THE RECEIVER

You should have the following items:

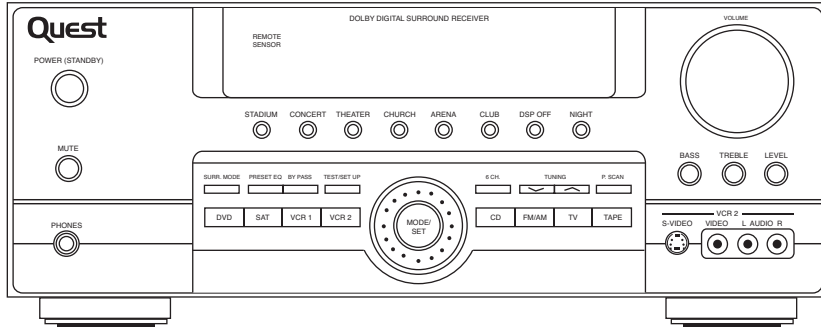

One Quest QSR5000 receiver unit

One external FM Dipole antenna

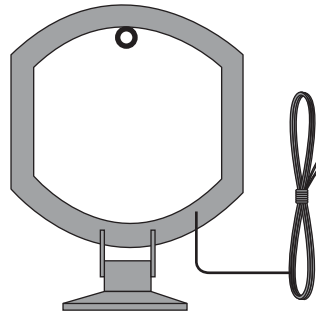
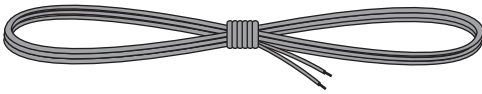

One external AM loop antenna

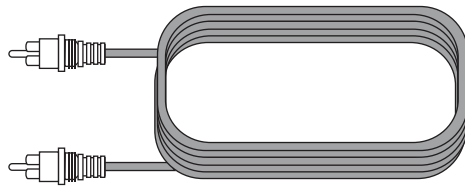

One video cable (single wire) with white RCA connectors

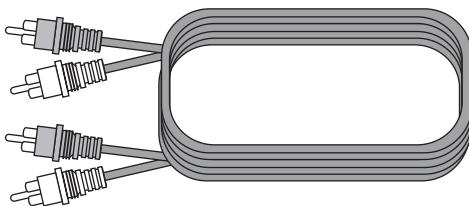

One audio cable (two wires) with red and white RCA connectors

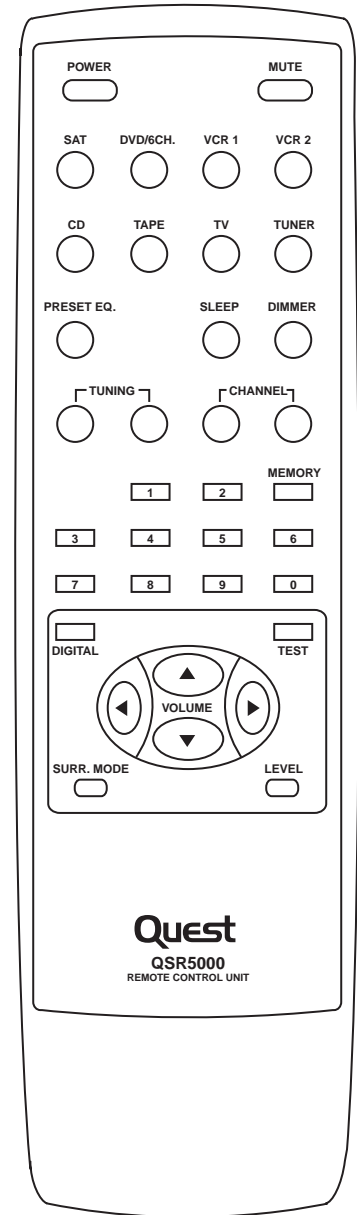
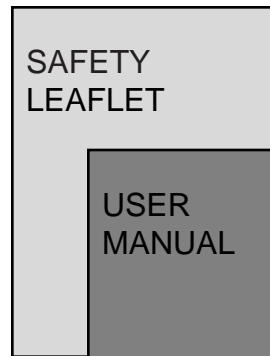

One remote control

- One instruction book
- One safety leaflet

GETTING STARTED

INSERTING BATTERIES INTO THE REMOTE

Insert two "AAA" batteries according to the + and - signs on the battery compartment. To use the remote control, point it directly at your receiver.

SET UP AND MAINTENANCE OF THE RECEIVER

- Provide spaces for sufficient ventilation as indicated:

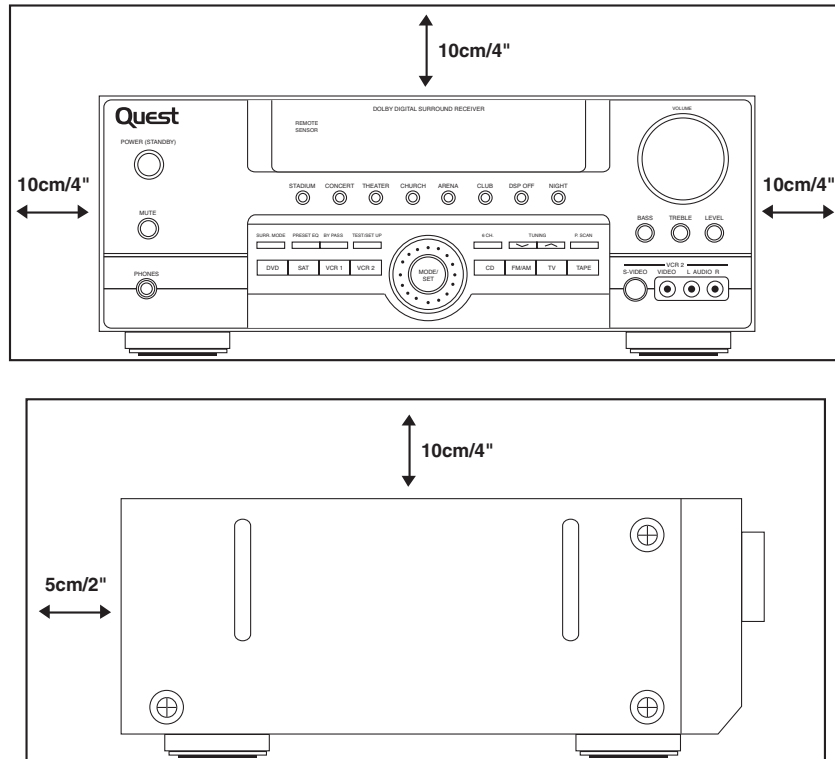

- Do not connect the AC power cords until all connections are completed.
- Do not use your receiver immediately after transferring it from a cold place to a warm place; there is risk of condensation.
- Do not expose your receiver to water and excessively high temperatures.
- After having disconnected your receiver, clean it with a soft cloth, or with a slightly damp leather chamois. Never use strong solvents.

PROTECT YOUR COMPONENTS FROM OVERHEATING

- Do not block ventilation holes in any component. Arrange the components so that air can circulate freely.
- Do not stack components directly on top of each other.
- Allow adequate ventilation when placing your components in a stand.
- Place your amplifier near the top shelf of the stand so heated air rising from it will not affect other components. If you have a satellite receiver, you should place it on the top shelf.

GETTING STARTED

CONNECTING TO AUDIO-VISUAL COMPONENTS

If your video component has a S-Video jack included you can make use of it to enjoy enhanced video quality by connecting it to the relevant S-Video jack at the rear side of the receiver. One video cable is needed for each component. When S-Video cable is used, composite video (yellow RCA connector) cable must also be connected for VCR recording.

NOTE: Before plugging in the optical cable or S-Video cable, make sure to match the shape of the plug and jack, otherwise, you will not be able to plug in completely.

If you have a SAT receiver, DVD player, or CD player with a digital output, you can make use of an optical digital connecting cord (not supplied) or coaxial digital connecting cord (not supplied) to carry the audio portion of the signal and enjoy Dolby Digital sound quality. One optical or coaxial cable is needed for each SAT receiver, DVD player or CD player. When optical or coaxial cable is used, the analog audio cables are still needed if recording through a tape or VCR is desired. This receiver provides one optical and one coaxial digital input for the connection of your components. Please connect your components (e.g. DVD, SAT, or CD) to the appropriate digital inputs and press FUNCTION and then rotate MULTIJOG to match your connection.

NOTE: Optical and coax cables carry only the audio portion of the signal. A video connection must also be established for a SAT receiver and DVD player. S-Video provides the best connection for the video portion of the signal. Composite video (yellow RCA connector) can also be used. It is important that the same type of cable (S-Video or composite) that is connected from the Home Theater to the TV is used to connect the SAT receiver or DVD player to the Home Theater.

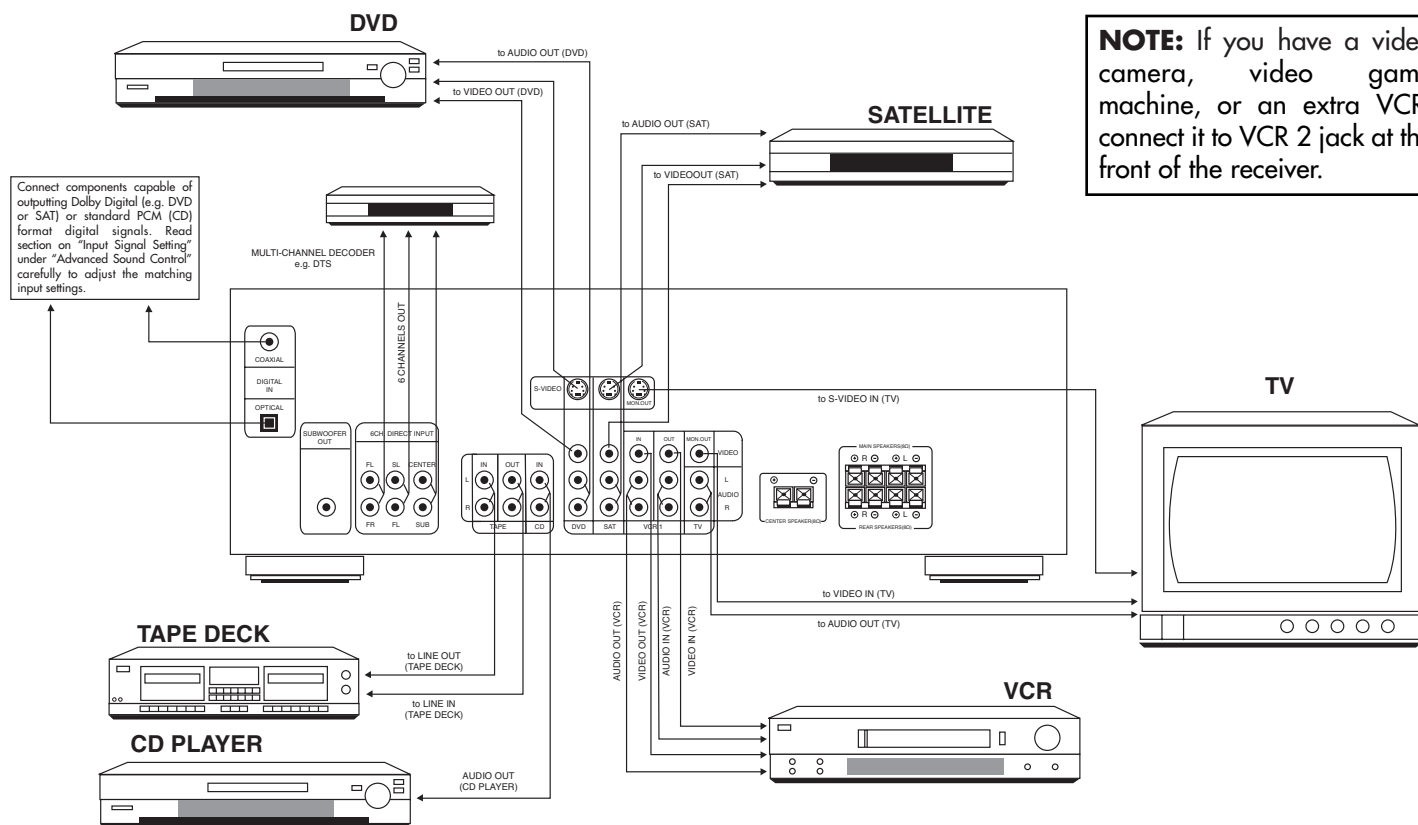

If your CD player is equipped with digital optical jacks, use of optical cable is preferred. What you need is just one more optical digital connecting cord (not supplied). Plug it in the digital input jack of the receiver and select OPTICAL on the receiver setting (see details on pg.18 chapter "Input Signal Setting"). You can enjoy better sound quality brought to you by the optical cable. When optical cable is used, analog cables are still needed for recording to tape output.

NOTE: This receiver has one digital optical jack only. Be sure that such connection does not prevent optical cable connection of other components (e.g. DVD & SAT)

GETTING STARTED

DIGITAL CONNECTION

Read instructions carefully when connecting components to the receiver.

Digital In Jacks can accept Dolby Digital (AC-3), or PCM signals when compatible components are connected

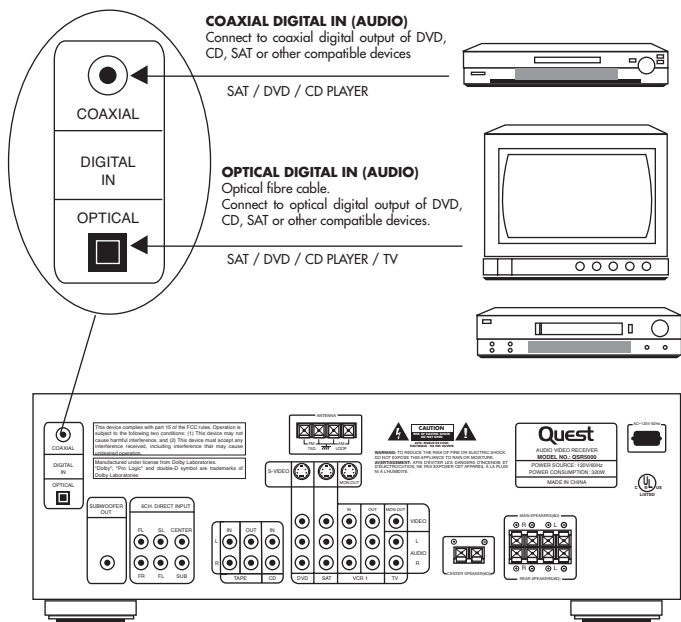

AM Loop antenna & FM indoor antenna

1. Uncoil the antenna wire and locate the base end.
2. Press down on the antenna tab to open the terminal.

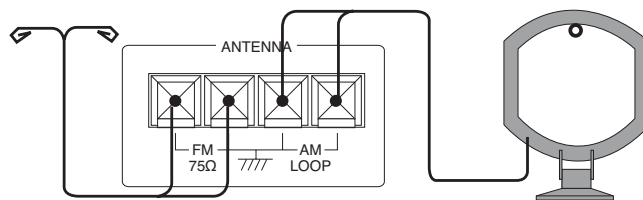

HINT

- For FM reception, extend antenna to its full length and arrange the Antenna in a T shape.
- For AM reception, rotate antenna horizontally to get better reception.

CONNECTING THE ANTENNAS

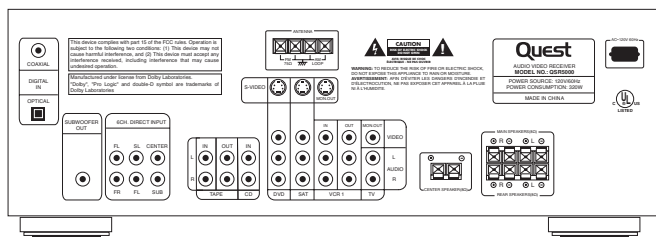

The AM and FM antennas connect to the AM and FM terminals on the system's back panel.

They must be hooked up in order to receive clear reception.

GETTING STARTED

CONNECTING THE SPEAKERS

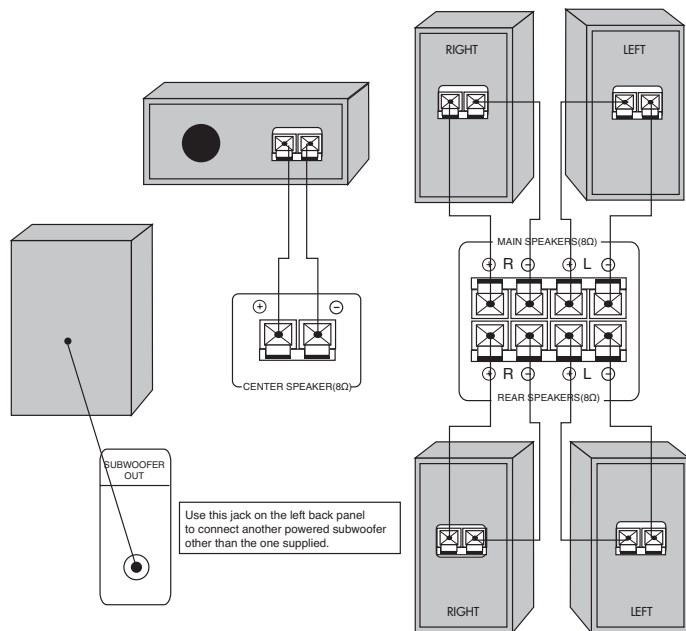

Speakers

You will need to use 6 speakers with the unit (2 front, 1 center, 2 rear, 1 subwoofer). In order to enjoy good surround effects all six speakers need to be connected to the receiver.

At least two front speakers (left and right) are required. For better sound quality, center speaker, rear speakers and subwoofer should also be connected. Adding center and rear speakers will enhance surround effects. Adding a Subwoofer will increase bass response.

If you want to enjoy full range of sound effects, with small speakers, it is a must to use the subwoofer with the speakers to maintain adequate bass signal.

Speaker cords

1 for each speaker is needed for connection. Twist the stripped ends of the speaker cord about 2/3" (15mm). Press down on the tab to open the terminal and insert the wire. Snap the tab closed.

To ease speaker connections, the terminals are color coded.

- Red/Black (Front Speakers)
- Blue/Black (Center Speaker)
- Grey/Black (Rear Speakers)

Connect the L, R speaker to the red/black terminal on the receiver. Do the same for the center (with blue/black terminal), rear speaker (with grey/black terminal).

Speaker polarity

When connecting the speakers, make sure the polarities ("+" speaker wire to "+" on the receiver) of speaker wires and terminals are matched. If the cords are reversed, the sound will be distorted and will lack bass ("out of phase" effect).

CONNECTING THE SUBWOOFER

To connect your own powered subwoofer, a mono aural audio cord (not supplied) is needed (RCA terminal).

This receiver offers a high flexibility for user to use a large variety of speakers and subwoofers. For more information please refer to section "Fine Setting of the Speakers" in "Advanced Sound Control" on page 18.

GETTING STARTED

POSITIONING YOUR SPEAKERS

1) Left & Right (Front Speakers)

They carry primary music and sound effects.

2) Center Speaker

In surround mode, the center speaker carries much of the dialogue as well as music and effects. It should be set between the left and right speakers.

3) Surround (Rear Speakers)

Their overall sound balance should be as close as possible to the front speakers. Proper placement is vital to establish an evenly distributed sound field.

Subwoofer

A subwoofer is designed to reproduce powerful low bass effects (explosions, the rumble of spaceships, etc.) which dramatically heightens involvement with the action on the screen. It is therefore recommended to connect subwoofers when small speakers are used.

Magnetic shielding

Speakers placed less than two feet from the TV set must be magnetically shielded in order to prevent picture distortion.

It is not recommended to place the rear speakers near the TV set.

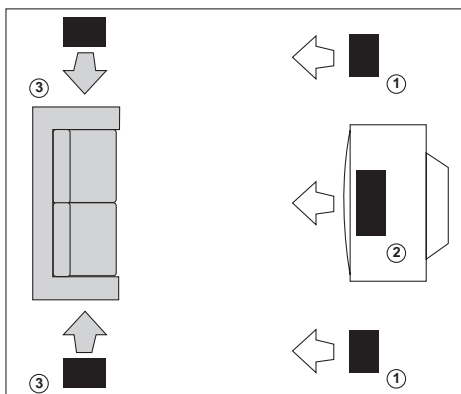

FRONT SPEAKER PLACEMENT

Even if you can't duplicate this ideal home theater setup exactly, the suggestions for speaker placement that follow will help you get good results.

Alignment

Align the center speaker evenly with (A), or slightly behind (B), the left and right speakers, but not ahead of them.

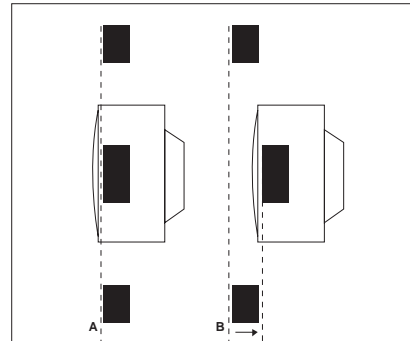

ADVANCED SETTING

Angle

Placing the left and right speakers to form a 45 degree angle with your favorite viewing position will duplicate the soundtrack mixer's perspective.

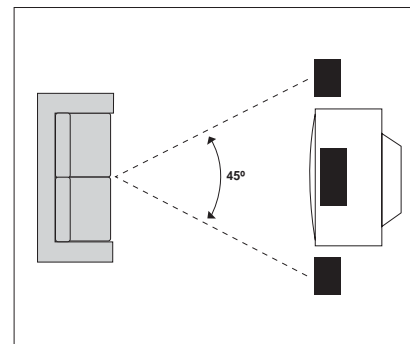

Height

The mid and high frequency drivers of the three front speakers should be as close as possible to the same height. This often requires placing the center speaker directly atop (A) or beneath (B) the TV set.

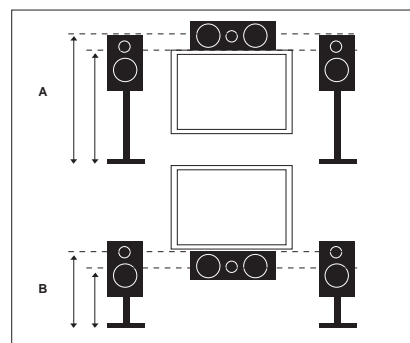

GETTING STARTED

PREFERRED SOUND PLACEMENT

Location

If possible, place surround speakers to either side of the listening area, not behind it.

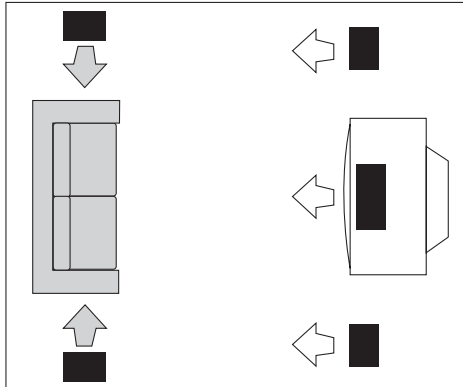

Height

If space permits, install surrounds 2-3 feet above viewers. This helps to minimize localization effects.

Aiming

Aiming surrounds straight across the room, not down at viewers, helps create a more open, spacious surround sound field.

ADVANCED SURROUND SETTING

ALTERNATIVE SURROUND PLACEMENT

Rear wall

If rear wall mounting is the only choice, aim the speakers at each other, towards the front or even towards the sidewalls. Experiment with placement until surround sounds seem to envelop you, rather than coming from behind you.

No adjacent walls

Surrounds can go on stands facing each other to approximate the preferred sidewall mounting, or to the sides or rear of the viewing area aimed upwards. In the latter case, they can go right on the floor, or preferably, a few feet off the floor such as on end tables.

TEST TONE/CHANNEL BALANCE

Channel balance

Your receiver is equipped with a test signal generator for balancing the channels. As the signal "travels" from channel to channel, adjust the level controls until each channel plays at the same loudness level. (For details see operation of test/setup)

Level adjustment & surround channel level expectations

Even though you adjust the surround channel to be as loud as the others on the test signal, you'll find that on actual program material the surround channel is usually much lower than the front. Don't be tempted to readjust the surround level; program producers use surround mostly for subtle atmosphere and ambience, and only rarely for special effects. A good surround mix doesn't call attention to itself; if it did, it would soon become distracting.

Connecting for power

Make sure you connect all your other electronic components and the speakers before plugging your receiver into the outlet. Plug the power cord in the wall outlet, matching the wide blade of the plug with the wide slot in the outlet. Be sure to insert the plug completely.

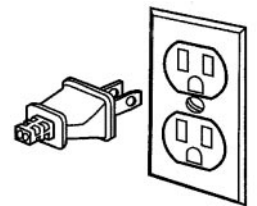

Using headphones

To listen privately through your audio system, use the PHONES jack on the receiver. However, make sure you turn down the volume before you put on the headphones. Increase the volume to the desired level after headphones are in place.

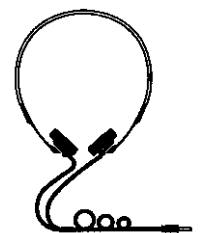

OPERATING YOUR RECEIVER

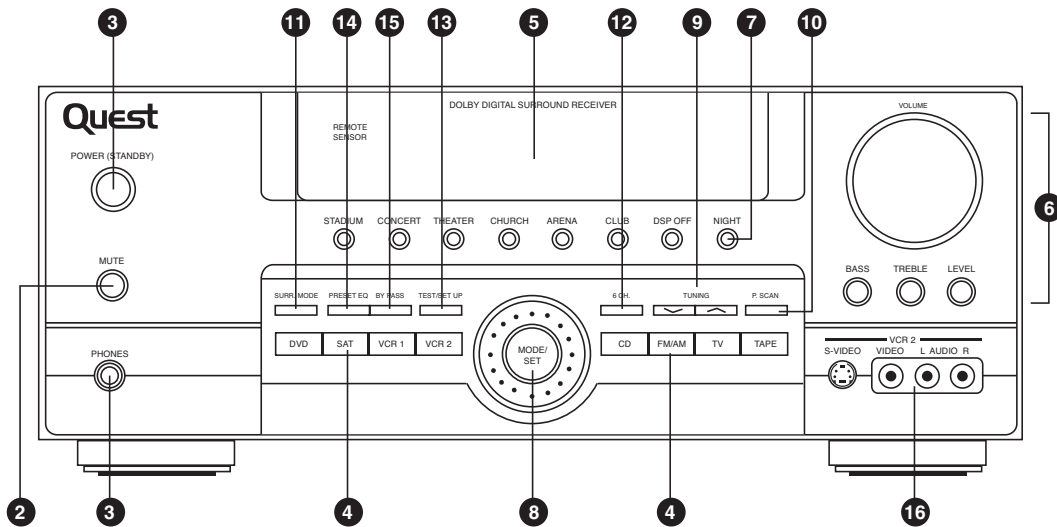

RECEIVER CONTROLS

1. Standby/On

To turn the unit on/off. When the system is turned on, the unit will go to the mode it was in before power off.

2. Mute

To mute all audio outputs.

3. Phones

Plug your headphones (not supplied) into it for your private enjoyment. Speakers will be off when phones are inserted.

4. Source Buttons

To select sound source. For e.g. CD, SAT, etc.

5. Display

To display current status of the receiver.

6. Sound Control

Lets you adjust the sound-volume, treble, bass & balance.

- To change the VOLUME, turn the large central knob.
- To adjust TREBLE or BASS, press relevant button and turn the knob.
- To change the volume of individual speaker, press LEVEL button repeatedly to select the speaker, then turn the knob to adjust the level. (Refer to "the TEST/SET UP button" on page 20)

7. DSP (Digital Sound Processor) & Night mode

Press corresponding button to select the DSP mode (STADIUM/CONCERT/THEATER/EARENA/CHURCH/CLUB/OFF) you want. (DSP will not function under DIGITAL input). Press NIGHT for your enjoyment at night (see page 18). (Night mode can be used only during dolby digital 5.1 mode).

8. Multi Jog, Mode/Set

When pressing MODE/SET repeatedly, the display will toggle among Audio Source (for DVD, SAT & CD), SLEEP mode and DIM selection.

Please refer on page 18 for "Input Signal Setting".

- In SLEEP mode, you can set the receiver to turn off after 30, 60, 90 or 120 minutes.

- In DIM selection, you can rotate to set the brightness of the display. Such settings will be stored.
- Use MULTI JOG for speakers and subwoofers setup and preset radio stations selection.

9. Tuning

Press for about 2 seconds to activate AUTOMATIC PRESET function. Press once to review all preset stations.

10. P. Scan (Preset Scan)

- Press and hold for about 2 seconds to start the automatic tuner station preset.
- Press to view preset stations one by one.

11. Surr. Mode

Press to select the sound mode that you want. (Refer to "Advanced Sound Control" on page 17).

12. 6 CH (6 Channels External Input)

Press to select the input connected to an external 6-Channel decoder.

13. Test/Set Up

When pressing it briefly, a short noise (test tone) will be generated in the speakers one by one. When keeping pressed for 2 seconds, it will enter SETUP mode for speakers and subwoofers. Rotate the MULTI JOG knob to choose the options. (Refer to "the TEST/SET UP button on page 20).

14. Preset EQ

Press repeatedly to select the desirable EQ mode (music style) CLASSIC/POP/ROCK/JAZZ/VOCAL/or FLAT. Your choice will be saved automatically. (EQ will not function under DIGITAL input).

15. Bypass

Press to go back to stereo sound (no DSP effect, no sound from center and surround speakers).

16. VCR2/Video Cam Input

For convenient use of your digital camera, family game machines, second VCR, etc.

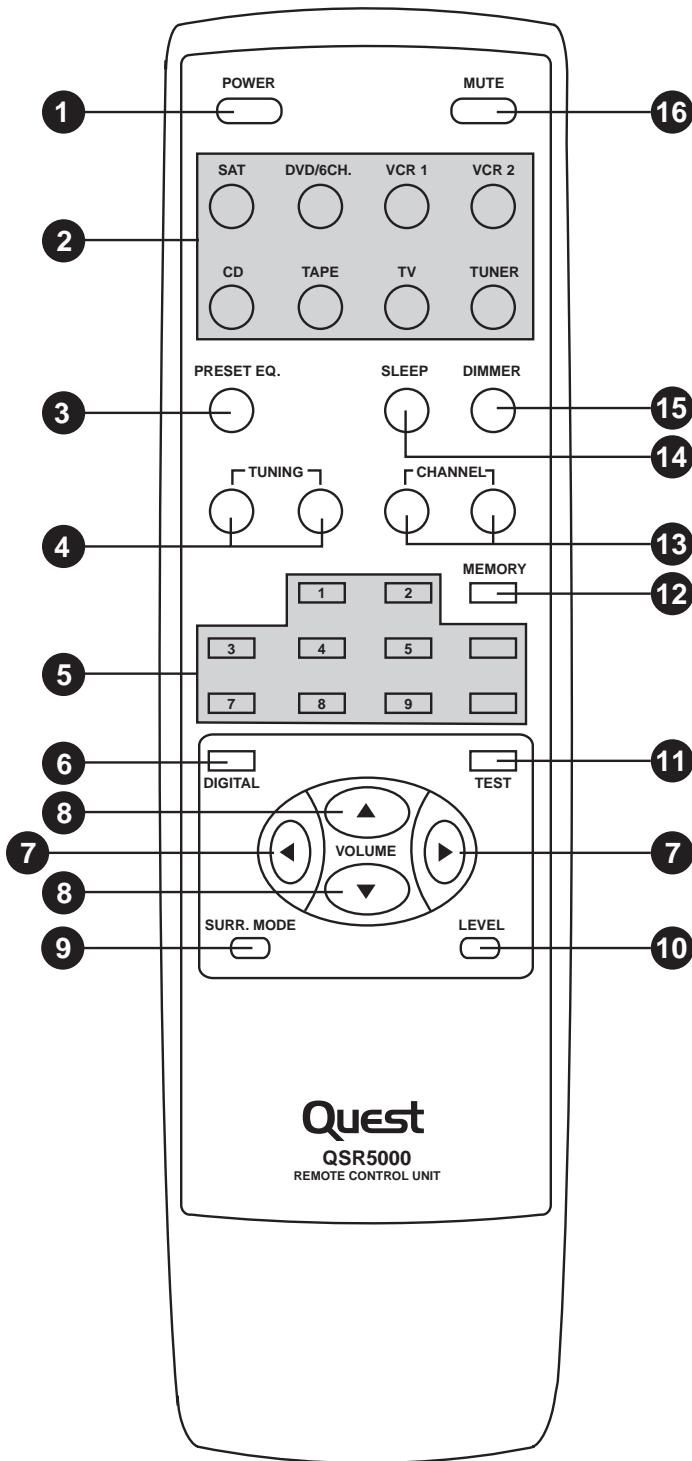

YOUR REMOTE CONTROL

1. On/Off

To turn on or off the receiver.

2. Source Buttons

To turn on and select various audio/video sources. You can also enter the 6 channels direct input mode by pressing DVD/6CH.

3. Preset EQ

4. Tuning

5. Number Buttons

To access directly a pre-set station or to peripheral devices (in TUNER mode).

6. Digital

Select the way your audio/video components are connected to the receiver (Analog, Optical, Coaxial or Input/Output).

7. Left/Right Arrow

Buttons used to adjust the receiver in the LEVEL modes.

8. Vol (Volume Buttons)

To adjust the volume

9. Surr (Surround Sound Control)

Press to change the surround sound settings. The display will toggle among DOLBY DIGITAL, DOLBY PROLOGIC, DOLBY 3 STEREO, STEREO and DSP modes.

10. Level

Press to adjust the volume of the individual speaker. Press repeatedly and the display will toggle among different channels (Left front speaker, Right front speaker, Center speaker, Left rear speaker, Right rear speaker and Subwoofer). Press the left and right arrow buttons adjustment.

11. Test

When pressing, a short noise (test tone) will be generated in the speakers one by one.

12. Memory

Used to manually store radio stations in the unit's memory.

13. Channel Up/Down buttons

Used to select programmed stations (in TUNER mode).

14. Sleep

Press repeatedly to put the unit in the sleep mode. Unit will scroll between 30, 60, 90 & 120 minutes with each press of the button.

15. Dimmer

Press repeatedly to change brightness of the display.

16. Mute

To mute all audio outputs

(For details, refer to section "Advanced Sound Control" on Page 17)

OPERATING YOUR RECEIVER



DISPLAY

DIGITAL

- Audio output is in Dolby Digital mode.

PRO LOGIC

- Audio output is in Dolby Pro Logic mode.

3 STEREO

- Audio output is in 3 Stereo mode.

STEREO

- Tuner stereo signal detected.

TUNED

- Tuner station detected.

DSP

Sound Source/Speakers icons

- Tuner station detected.

 → The letter indicates the input source of this channel.

 → The square box indicates which speaker is active.

SLEEP

- Unit is in Sleep mode.

KHz

MHz

- tuner frequency unit.

OPERATING YOUR RECEIVER

SWITCHING ON/OFF

- To switch to the receiver, press **STANDBY/ON** button once. Alternatively, you can press any of the source buttons to power on the receiver.

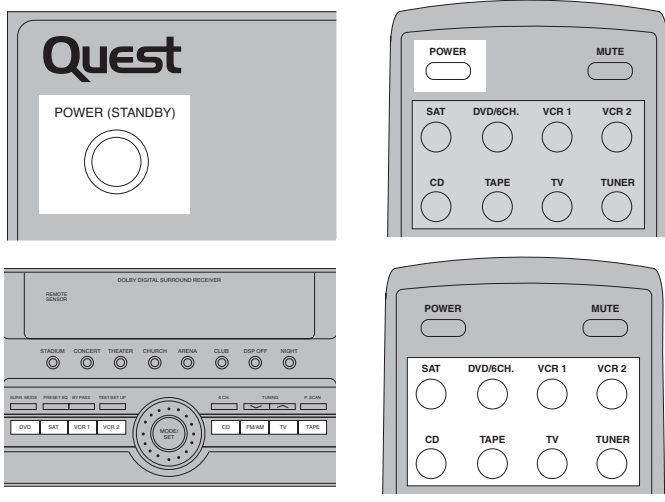

- Standby:** when the receiver is on, press the **STANDBY/ON** button once to activate the standby mode.
- To switch off the unit completely, unplug the power cord from the socket.

NOTE:

Your receiver has a back up memory to keep your settings like preset radio station for about 2 weeks in case electricity cut occurs. If the receiver is unplugged for more than 2 weeks, all the settings will be lost and re-setting will be necessary.

SELECTION OF AUDIO/VIDEO SOURCE

When one of the source buttons is pressed, the audio and video input corresponding to the name will be activated.

The receiver acts as a switching device between all the sources that are plugged into to it.

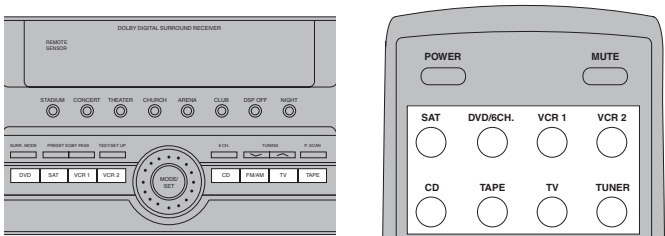

Example 1:

If you connect a DVD player to the DVD input (audio & video) on the receiver and press the DVD button, you will be able to have the sound and image transmitted by the DVD.

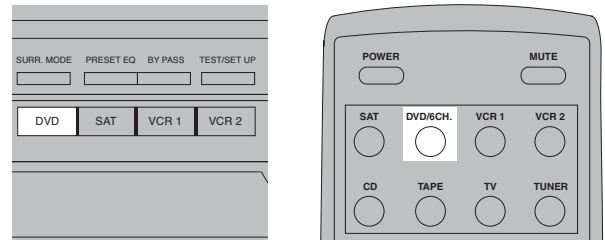

Example 2:

Based on example 1, the DVD is playing, if a VCR is connected to the VCR 1 input (audio & video) of the receiver and the VCR1 button is pressed, image and sound from the VCR source will replace the DVD.

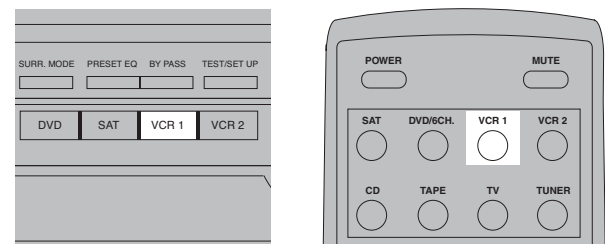

You can connect up to 7 audio/Video sources to this amplifier.

Source Button (Receiver front panel)	Corresponding Connector (Receiver back panel)
DVD	DVD IN (audio/Video)
SAT	SAT IN (audio/Video)
VCR-1	VCR-1 IN (audio/Video)
VCR-2	VCR-2 IN (audio/Video)
CD	CD IN (audio/Video)
TV	TV IN (audio/Video)
TAPE	TAPE IN (audio/Video)
FM/AM	Built-in

OPERATING YOUR RECEIVER

When a source is selected, the source name will be shown on the display.

Example:

Press DVD to select DVD as the source to the amplifier.



NOTE:

1) Your receiver has a built in tuner. Just connect the appropriate antenna on the back of the receiver and you will be able to listen to radio stations. (See details in Tuner section).

2) Other sources can be connected to the above standard source.

Example:

You can connect an LD into the DVD inputs.

3) Refer to the "Connecting to Audio-Visual Components" section for details on connection.

USING THE RECEIVER TO PLAY A SOURCE

After having properly connected a source (DVD, CD, VCR) to the receiver, you can partly control them through the receiver.

Playing a DVD with the receiver

1) Connect a DVD player to the receiver (see connecting your receiver for details).

NOTE:

To play Dolby Digital sound, the source must be Dolby Digital encoded and connected to the receiver via the optical or coaxial terminal (see "Digital Connection" on page 5 for details).

2) Press STANDBY/ON to switch on the receiver.

3) Select the DVD source by pressing the DVD source button.

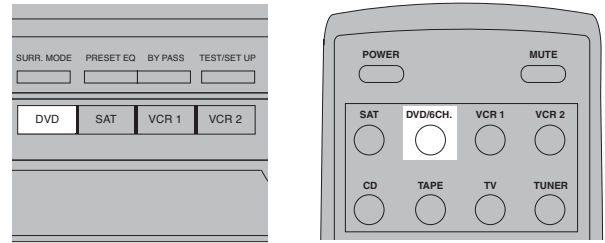

4) Switch on the DVD player and start playback.

5) Switch on your TV.

6) Select the appropriate A/V channel on the TV (refer to your TV manual for details) until the image from the DVD player is displayed.

7) Set the sound mode if needed (see "Advanced sound control" on page 17 for details).

ATTENTION: If you connect the DVD and Receiver with ANALOG signal (RCA cord). Please make sure to turn on ANALOG output in your DVD player.

Example 1:

To play 5.1 Dolby Digital surround sound press the Surr. mode button until "Dolby Digital" appears on the display and all of the speakers icons light up.

Example 2:

DVD: You may also need to select the Dolby Digital 5.1 on the DVD disc menu to have the digital surround enabled providing that the disc is encoded with Dolby Digital 5.1 (please refer to the DVD player and DVD disc instruction.)

ATTENTION: To play Dolby Digital, you must connect the DVD and the receiver with DIGITAL signal (Coaxial or Optical). Not ANALOG (RCA cord).

Example 3:

LD: You may need to select a different Audio Channel on your LD (refer to your LD player manual.)

8) Adjust volume knob accordingly.

OPERATING YOUR RECEIVER

OPERATING THE RADIO

The receiver has a built-in tuner that allows for AM/FM radio function.

Manual Tuning

1) Connect the FM and AM antenna accordingly (See "Connecting the Antennas" section on page 5 for details).

2) Press STANDBY/ON to switch on the receiver.

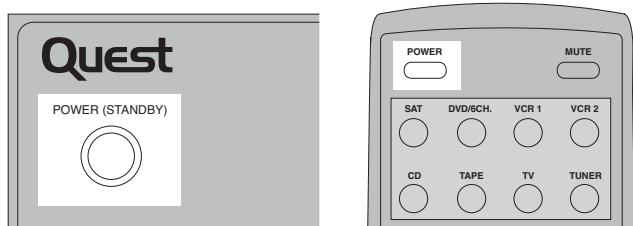

3) Press FM/AM or press TUNER on the remote.

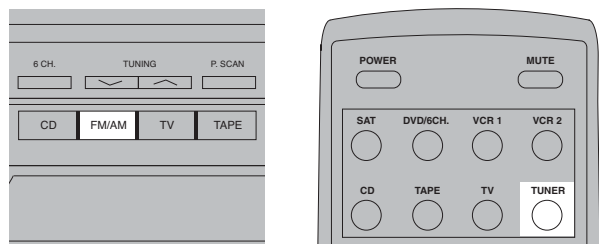

4) To select band, press the FM/AM button or press TUNER on the remote again to toggle between FM/AM mode.

When an FM station broadcast stereo sound, STEREO is displayed.

5) Tune the stations by pressing TUNING UP or TUNING DOWN repeatedly until the desired station is found. Alternatively, you can press and hold TUNING UP or TUNING DOWN for about one second to activate the automatic SEARCH function. In this mode the receiver will automatically tune frequencies until it finds a station.

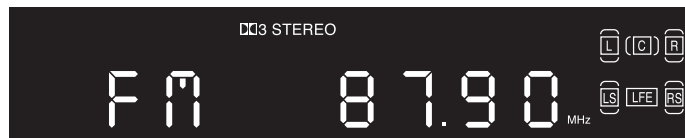
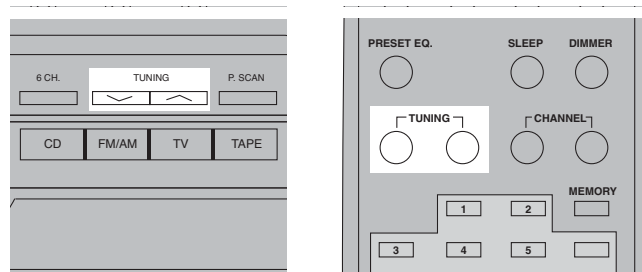

6) Repeat steps 4 & 5 to tune another radio station.

Select sound effects if needed by pressing PRESET EQ or DSP sound (See "Advanced Sound" section for details).

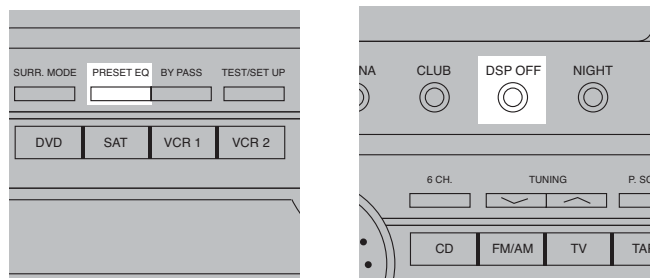

NOTE:

1) If there is interference, modify the location of the antenna until the optional sound is heard. TV and other electronic devices could be the cause of the interference, so try to position the antenna away from them.

2) A weak signal can affect the "Auto Search" function. Adjust the antenna for better reception for more efficient search.

OPERATING YOUR RECEIVER

Storing Radio Stations:

The receiver can store up to 30 radio stations in memory. You can enter every single radio station yourself or the receiver can store all available radio station automatically in an ascending order.

Automatic Preset Storing

1) Select the band wave by pressing Tuner repeatedly.

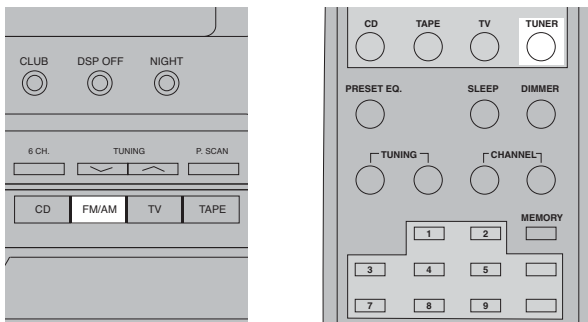

2) Press and hold P.SCAN for 3 seconds.

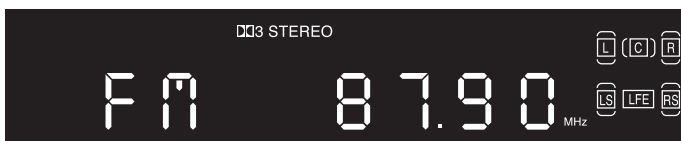
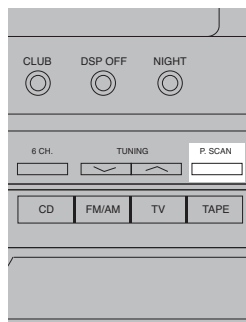

Radio frequencies will be browsed and radio station stored automatically. When all available radio stations are stored or if all 30 memory locations are full, the auto preset will stop.

NOTE:

Weak signal can affect the "Automatic Preset Storing function" efficiency. Adjust the antenna for the best reception for more efficient search.

Manual Preset

- 1) Select the band wave by pressing TUNER repeatedly.
- 2) Tune to a radio station (see "Manual Tuning" on page 14 for details).
- 3) Press MEMORY on the remote control. "MEM" will appear on the display.

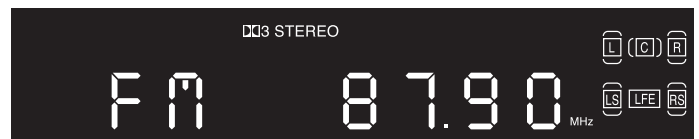
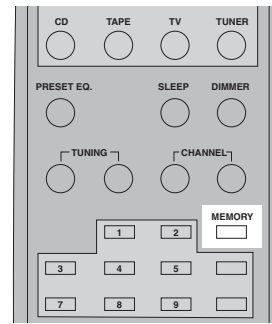

4) While the word "MEM" is still on, input your desired preset number (1-30) using the numeric keys on the remote control to store the radio station.

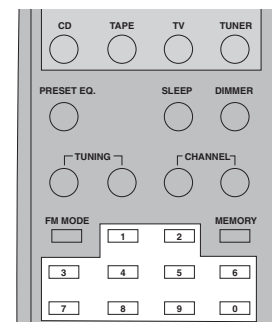

OPERATING YOUR RECEIVER

Retrieving Preset Stations

1) Press FM/AM to select tuner mode.

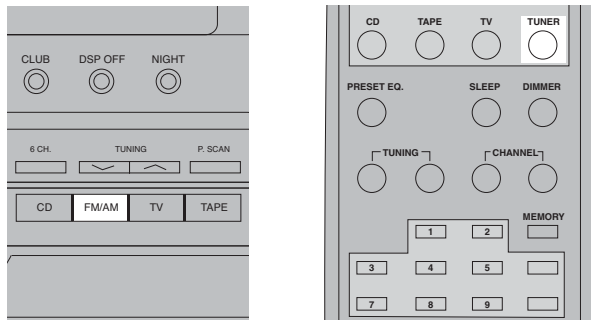

2) Rotate MULTI JOG on the receiver or press CH+ or CH- buttons on the remote to select preset stations.

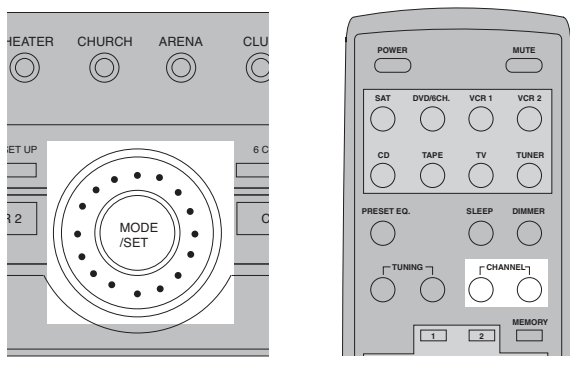

To activate the 6 channel external input, press 6 CH on the receiver or press the DVD/6 CH button on the remote control twice.

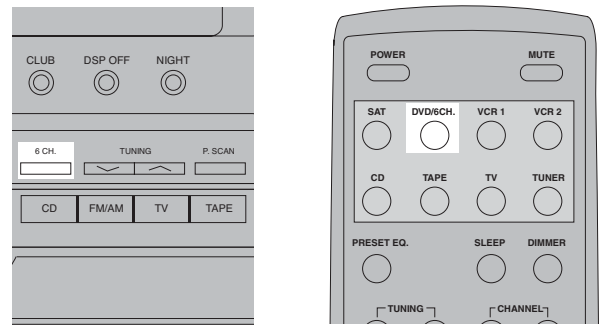

ATTENTION: With 6 Channel input, all DSP, EQ, and surround sound modes (Stereo, 3-Stereo, Dolby Prologic or 5.1 Channel) cannot be activated.

Channel External Input

An external decoder (DTS, Dolby Digital, etc...) or a device with built-in multi-channel decoder and 6 channel output connector (DVD player, TV...) can be connected to the 6CH input. It is therefore possible to play any future 6 channel codings (SACD, DVD audio) thanks to this connection. The external decoder device will send the separated audio information to the receiver that will then amplify the signal and send it to the appropriate speakers.

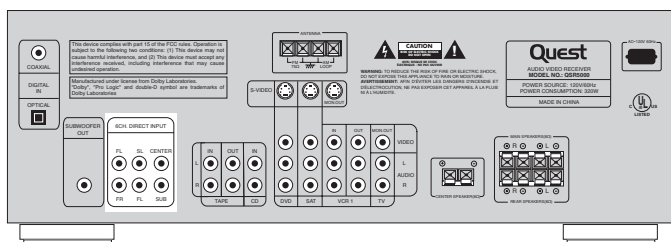

ADVANCED SOUND CONTROL

SOUND ENHANCEMENT SYSTEMS

This receiver is equipped with several built-in sound enhancement systems.

Dolby Pro Logic and Dolby 3 Stereo

This surround system reproduces theater-like surround sound from Dolby-encoded software. The Pro Logic mode uses the built-in circuit to steer the Left, Center, Right and Surround channel audio signals and uses all 5 speakers and an optional subwoofer to play decoded Dolby Pro Logic program sources such as a TV and VCR.

ATTENTION: To play Dolby Pro Logic, you must have 5 speakers connected.

The 3-Stereo mode will redirect the surround signals to the front left and right speakers when only the front and center speakers are used.

ATTENTION: To play 3-Stereo, you must have 3 speakers connected.

Use this mode to suit your speaker system configurations (such as size and number of speakers) and type of program (such as VCR).

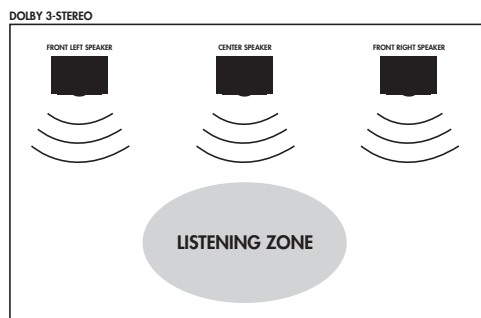
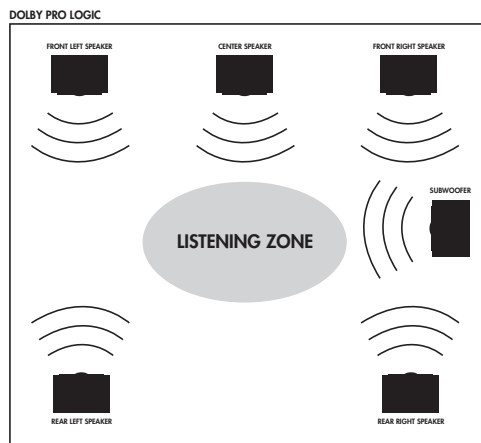

Dolby Digital

The Dolby Digital mode lets you enjoy full digital surround from software processed in the Dolby Digital format. Dolby Digital provides better sound quality and more powerful presence than conventional Dolby Surround.

This unit is equipped with Dolby Digital 5.1-channel so that you can enjoy enhanced full digital surround sound. Being different from Dolby Pro Logic in which only four channels (Front Left, Front Right, Centre and Rear) are used, the new system provides stereo separation of the rear speakers (Rear-Right, Rear-Left). These 5 channels, together with the subwoofer channel for bass sounds (counted as .1 channel), constitute as 5.1-Channel (or 6 Channels) input for Dolby Digital that brings you the most sophisticated sound enjoyment.

ATTENTION: To play Dolby Digital 5.1, you must connect the DVD to your receiver with digital signal (Coaxial or Optical) + the sound source (DVD software) must be 5.1 encoded.

Recording Dolby Digital Source

To record from a digital (Optical or Coaxial) input using a VCR/Tape that is connected to the receiver, the sound must be set to stereo first. Press SURR. MODE to select stereo mode.

If the receiver is set to 5.1 sound information recording from surround speakers, the center speaker will not be recorded.

ADVANCED SOUND CONTROL

Stereo

The stereo mode uses the two main channel outputs from the front of the speakers. Use this mode if you have connected the front speakers only.

DSP (Digital Sound Processor)

These digital sound effects resemble sounds in a real environment such as Stadium, Concert, Theater, Arena, Church, Club. DSP automatically converts analog audio signals to digital ones which enables you to adjust the sound without degrading the sound quality. Different modes will give you different feel of size and type of listening environment. (Not available in Dolby Digital (DVD) or during Digital input).

Night Mode

By using Dynamic Range Compression technology, you can enjoy enhanced sound quality by Dolby Digital at night without interrupting your roommates or neighbors. While enjoying a Dolby Digital enabled component (DVD, SAT), you can activate NIGHT MODE by pressing the NIGHT button on the front of the receiver and this mode will compress the difference in volume between normal voices and sounds like explosions.

ATTENTION: Night Mode can be functioned only during Dolby Digital 5.1 playback.

FINE SETTING OF THE COMPONENTS

The receiver has pre-selected the best surround mode for you once you turn on the unit by pressing the SOURCE Buttons (like DVD, SAT, CD) directly. If you decide to change the surround mode, you can press the SURR. MODE button repeatedly to toggle among the different surround mode choices and select the one you want.



ATTENTION: To play Doby Digital 5.1, you must connect the DVD to your receiver with a digital signal (Coaxial or Optical) + the sound source (DVD software) must be 5.1 encoded.

Input Signal Setting

The receiver defaults to the most convenient settings for your easiest use (see table).

If your connection is different from the default setting:

- 1) Select the source
- 2) Press MODE/SET
- 3) Rotate MULTI JOG to toggle among Optical/Coaxial/Analog to match your connection. Your selection will be stored automatically.

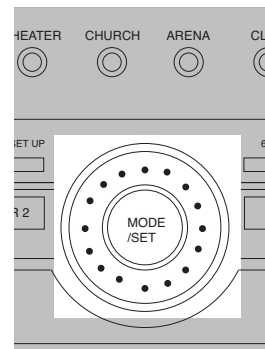

Every time you press the source button, the input setting (e.g. DVD/OPTI) will be shown on the display for a few seconds.

Source Button	Default Input (As seen on Display)
• SAT	Analog (SAT/ANA)
• DVD	Analog (DVD/ANA)
• CD	Analog (CD/ANL)
• VCR-1	Analog (VCR1/ANL)
• VCR-2	Analog (VCR2/ANL)
• FM/AM	Built-in Tuner
• TAPE	Analog (TAPE/ANL)
• TV	Analog (TV/ANL)

Digital Input

Select this setting to play digital signals from a DVD, CD, LD player, SAT or TV.

NOTE:

Digital input is only available for DVD, SAT, CD and TV.

ADVANCED SOUND CONTROL

Input Signal Selection

Select this setting to play analog signals from a cassette deck, VCR or turntable.

Source Button	Available Input
• SAT	ANL/Optical/Coaxial
• DVD	ANL/Optical/Coaxial
• CD	ANL/Optical/Coaxial
• VCR-1	ANL /-/-
• VCR-2	ANL /-/-
• TAPE	ANL /-/-
• TV	ANL/Optical/-

The Test/Set Up button

You can adjust the relative loudness of the speakers by TEST/SET UP button. In Dolby modes, press the button briefly. A short noise will be heard in the speakers one by one. The speaker playing the noise at that moment will be shown in the display.

Speaker Configurations

You can also change the setup of the speakers by pressing the TEST/SET UP button until the display shows "LARGE" or "SMALL" which enables you to set the size of the speakers.

Press again, "SW" will be displayed and you can set the subwoofer on or off.

Displaying Program Formats

When a digital source is playing, the receiver will automatically switch to the proper surround mode and indicates on the speaker icons on the right hand side of the display.

It is important to note, however, that not all Dolby Digital sources are encoded with full complement of 5 channels plus LFE*. Speaker icons show how many and which speakers you have enabled and the letters inside the speaker icons show which channel is present in the source information.

*LFE stands for Low Frequency Effect. The indication "LFE" appears if the digital source contains LFE information. In this case, the bass signal will be delivered to the subwoofer, offering more dynamic deep bass sound effects. If the letter is flashing, the signal is either too weak or just gone.

CARE AND MAINTENANCE

RECEIVER/TUNER OPERATION

Stereo indicator is off.

- Adjust the antenna

The signal is Mono. Severe hum or noise

- The signal is too weak. Connect an external antenna.

The Test/Set Up button

You can adjust the relative loudness of the speakers by TEST/SET UP button. In Dolby modes, press the button briefly. A short noise will be heard in the speakers one by one. The speaker having the noise at that moment will be shown in the display.

REMOTE CONTROL OPERATION

The remote control does not operate the unit.

- Another function mode is selected on the remote. Press the correct Source button.
- No batteries installed.

Install the batteries before attempting to operate the remote. Be sure to match the + and - ends of each battery to the symbols shown in the remote battery compartment.

- The batteries are weak.

Replace all batteries.

- The remote is pointed at the remote control sensor on the main unit or there is an obstacle between the remote and the main unit.

- The remote control is too far from the main unit, move closer.

GENERAL

No Audio.

- Make sure the speakers are connected.
- Check the input connections.
- Check the power cord connections.
- Make sure the MUTE indicator on the front panel is off.
- Make sure that the digital setting (Optical/Coaxial/Analog) is correct.

No Audio from one channel.

- Check the speaker level setting.
- Check the speaker wire or cable connections.

Noise occurs when the TV is turned off.

- The TV is too close to the audio system.

Specific instruments sound displaced.

- Check the connections between the receiver and the speakers if the sound does not match the video.
- Press the SOURCE button for the video source.

CLEANING THE EXTERIOR

Disconnect the system from AC power before cleaning the exterior of the system with a soft dust cloth, or with a slightly dampened leather chamois. Never use strong solvents.

EQUIPMENT SPECIFICATIONS

Amplifier Section:

All 5 channels: 100W at 8 ohm. 0.9% THD @ 1kHz

Subwoofer Channel: Line out

Muting Attenuation: 65dB

Frequency Response: 40Hz - 6MHz @ +/- 3dB

Signal to Noise Ratio: 65dB (Bypass mode)

Video Section:

Input (Sensitivity/Impedance): 1Vp-p/75 ohm

Output (Level/Impedance): 1Vp-p/75 ohm

Frequency Response: 10Hz - 6MHz @ +/- 3dB

Signal to Noise Ratio: 40dB

Crosstalk @ 3.58MHz: 40dB

AM Tuner Section:

Frequency Response: 80Hz - 2KHz @ +/- 6dB

Usable Sensitivity: 800uV/m @ S/N 20dB

Signal to Noise: 38dB

Image Ratio: 27dB @ 1000KHz

IF Rejection: 35dB

FM Tuner Section:

Frequency Response: 40Hz - 15KHz @ +/- 3dB

Quieting: 24dBu

Signal to Noise: 60dB (stereo)/65dB (mono)

Image Ratio: 40dB

IF Rejection: 50dB

LIMITED WARRANTY

Quest warrants this product to be free from manufacturing defects in material and workmanship under normal use for a period of 1 year from date of purchase, if service is required during the first year of ownership, product should be returned to the store where it was purchased with the original receipt for an exchange.

This warranty does not apply to any Quest product which is used for commercial, rental, or industrial purpose, is damaged by accident, misuse, abuse, improper line voltage water lightning, or any acts of God. This warranty is void if product is altered, modified, or if any parts of service covered by this warranty are furnished by anyone other than Quest. This warranty does not cover cartons, carrying case, batteries, cosmetic parts, broken or marred cabinets, magnetic tapes, compact discs, or any other accessories used in connection with the product or consequential damages due to defect in the product.

This warranty is not transferable and only applies to the original purchase. Any implied warranties, including the warranty of merchants, are limited in duration to the period of this expressed warranty and no warranty whether express or implied shall apply to the product thereafter. Under no circumstance shall Quest be liable for any loss or consequential damage arising out of the use of this product.

Quest

21000 TransCanada • Baie D'Urfé • Qc • Canada • H9X 4B7

Tel.: (514) 457-2555 • Fax: (514) 457-0055

Toll Free Order Number: 1-800-567-3275 • Toll Free Fax Number : 1-866-457-5507

IMPORTANT SAFETY INSTRUCTIONS

Some of the following information may not apply to your particular product; however, as with any electronic product, precautions should be observed during handling and use.

- Before using the product, please follow and adhere to all warnings, safety and operating instructions located on the product and in the user book. Save all instructions for future reference.
- Do not expose product to rain and do not use near water; such as, sink, wet basement, swimming pools, etc.
- Always leave sufficient space around the product for ventilation. Do not place product on a bed, rug, in a bookcase or cabinet that may prevent air flow through the vent openings.
- Do not expose product to extreme temperatures such as found near a hot radiator or stove, or in a car parked in the Summer sun.
- Connect power cord only to AC power source as marked on the product.
- Some products employ a polarized AC line plug (one blade is wider). This is a safety feature. The plug will go in the power outlet only one way. If the plug doesn't go into the outlet completely, turn the plug over and put it in the other way. If it still doesn't fit, contact a qualified electrician to change the outlet. Do not defeat the safety purpose of the polarized plug.
- Route power cord to prevent it from being pinched, or walked on, or melted by a hot stove or radiator.
- To clean cabinet, unplug AC power cord, then use a soft cloth dampened only with water.
- Do not place lit candles, cigarettes, cigars, etc. on the product.
- Unplug AC power cord from outlet during a lightning storm or when product is left unused for a long period of time to prevent damage due to lightning or power line surges.
- Care should be taken so that objects do not fall and liquids do not spill into the product.
- Never add accessories that the product has not been designed to accommodate.
- Use only the manufacturer's approved mounting instructions and hardware when installing product.
- Do not attempt to disassemble the cabinet. This product does not contain customer serviceable components.
- Do not handle the unit or power cord when your hands are wet or damp.
- Carts and Sands - The appliance should be used only with a cart that is recommended by the manufacturer.
- An appliance and cart combination should be moved with care. Quick stops, excessive force, and uneven surfaces may cause the appliance and cart combination to overturn.
- Damage Requiring Service - This product should be serviced by qualified service personnel when:
 - A) The power supply cord or plug has been damaged.
 - B) Objects have fallen, or liquid has been spilled into the product.
 - C) The product has been exposed to rain.
 - D) The product does not appear to operate normally or exhibits a marked change in performance.
 - E) The product has been dropped, or the cabinet damaged.
- When service or repairs are completed, ask the service technician to perform the safety check described in the service manual and to confirm that replacement parts have the same safety characteristics as the original parts.
- **IF YOUR PRODUCT OPERATES ON BATTERIES**, adhere to the following precautions:
 - A) Any battery may leak electrolyte if mixed with a different battery type, if inserted incorrectly, or if all batteries aren't replaced at the same time.
 - B) Any battery may leak electrolyte or explode if disposed of in fire or an attempt is made to charge a battery not intended to be recharged.
 - C) Discard leaky batteries immediately. Leaking batteries can cause skin burns or other personal injury. When discarding batteries, be sure to dispose of them in the proper manner, according to your state and local regulations.
- **IF YOUR PRODUCT IS EQUIPPED WITH ANTENNA TERMINALS**, and if an outdoor antenna is connected, be sure the system is grounded so as to provide some protection against voltage surge and built-up static charges. An outdoor antenna should be located away from power lines.
- **IF PRODUCT IS TO BE CONNECTED TO A CATV SYSTEM**, call the CATV system installer's attention to Article 820-40 of the NEC that provides guidelines for proper grounding and, in particular, specifies that the cable ground shall be connected to the grounding system of the building, as close to the point of cable entry as practical.

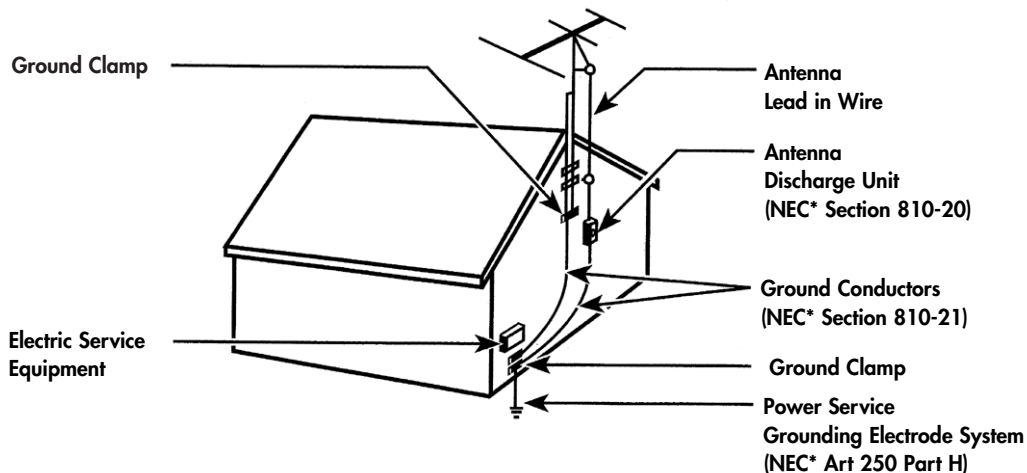

Antenna Grounding According to the National Electrical Code